

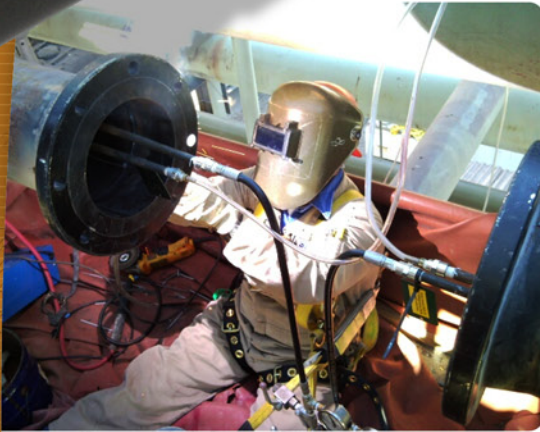

Line Isolation & Localized Hydrostatic Testing

State-of-the-art tool designs are developed with built-in safety features and focus on efficiencies for field operations. All our designs are backed by highly-skilled and trained personnel, making Furmanite today's choice for line isolation and localized hydrostatic testing.

When others say it can't be done, call on Furmanite to engineer solutions for the most challenging applications. Our unique tool designs, including specialized equipment for external testing of nozzle additions, are revolutionizing the industry.



Line Isolation and Localized Hydrostatic Weld Testing – One Tool, Two Applications

→ **Standard tool sizes from 0.5" to 36". We can create custom capabilities up to 120"**

Line Isolation:

- Standard tools are back-pressure rated to 25 psi. Custom tools are rated up to the burst pressure of the pipe.
- Standard tools include locking jaw, locking lug and long-stem designs for various sizing requirements.
- Tool can be utilized as a pressure-rated back-pressure isolation device.

Localized Weld Testing:

- Standard tooling tests pressures to 1,150 psi
- Custom tooling test pressures to 5,000 psi
- Localized hydrostatic test uses minimal amounts of water and provides a high degree of accuracy and safety.

FURMANITE®

MAXIMIZING ASSET UPTIME™

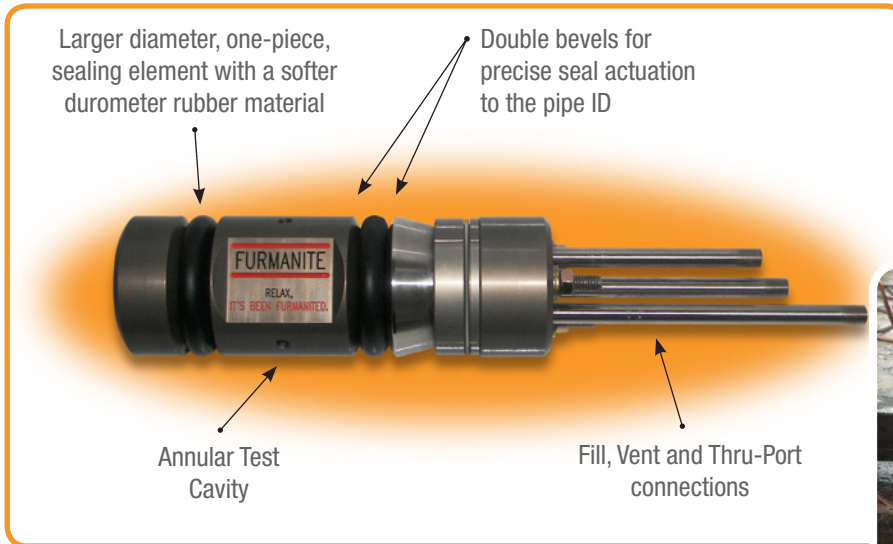

The Furmanite Advantage

- Standard tools are built with a multi-schedule design. This unique design produces a smaller footprint and allows for easy installation and removal.
- Wider sealing elements provide the ability to isolate in conditions where the pipe is pitted, corroded, eroded and out of round. These elements allow us to maintain seals on seamed pipe.
- Ability to monitor the annular area of the tool in order to verify isolation
- Ability to through-port any up-stream gas, vapor or pressures away to a safe environment, as well as purge through the center.

Localized Hydrostatic Nozzle Testing

Traditionally, nozzle additions for existing columns, vessels, tanks or liners are tested hydrostatically by filling the entire asset with water and performing an internal hydro – a practice which covers internal pressure and applies tensile hoop stress to the weld. It is supported by the first chapter of the Engineering Handbook.

But the first solution is not the only solution, and Furmanite has looked past the first chapter to focus on external pressure by applying compressive hoop stress to the weld; a process found in chapter two of the Engineering Handbook. This new technology has allowed Furmanite to develop a process that is a safe, efficient and more cost-effective solution for your needs.



OD nozzle test pictured above was accomplished on a 2", 300#, nozzle on a 16" propane line; the test utilized inflatable seal technology to perform a localized hydro test of the full penetration weld on the 16" pipe

Fully supported by the necessary calculations in order to meet the requirements of the most stringent engineering departments and authorized inspectors, Furmanite's proprietary process allows for the following capabilities:

- Simultaneous testing of the flange to nozzle weld and the full-penetration weld
- No confined space entry required, allowing for other craft to work simultaneously in the area
- OD Nozzle tester replicates all of the same hydrostatic pressures and stresses of a conventional hydro-test
- Provides the ability to apply axial load to the full penetration weld
- Reduces traditional preparation and test times associated with conventional internal hydrostatic test methods
- Minimal water usage required; reducing disposal costs
- Standard Outside Diameter nozzle test capabilities include 0.75" thru 36" nozzles or flange to pipe welds at pressures up to 2,500 PSIG.

Exterior Nozzle Testers:

Simplify the pressure testing of weld beads on flanges, spool pipes, and pressure vessels with exterior nozzle testing tools and service available from Furmanite

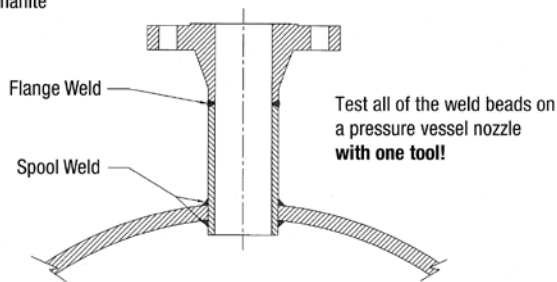

FIGURE 1:

Cross-section of a 2" ANSI B16.5 Class 300 flange welded onto a $\varnothing 24"$ pressure vessel

Testing with Exterior Nozzle Testers:

A flange gasket or seal is compressed between the nozzle tester body and the pressure vessel flange by torquing up flange nuts on studs. The nozzle tester body is pulled against the vessel and creates a seal when the face seal is compressed. The test cavity can be pressurized to validate the integrity of the weld beads. The flange and pipe spool welds carry all of the forces generated during testing.

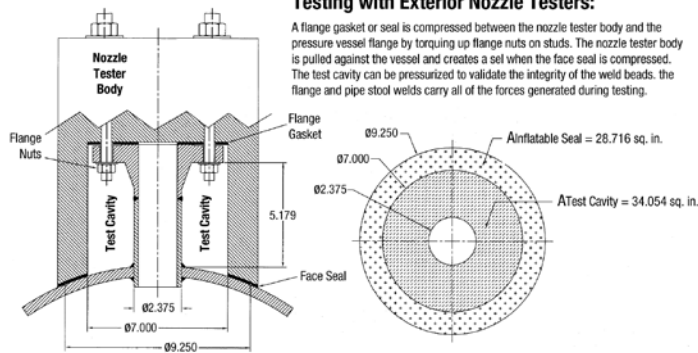
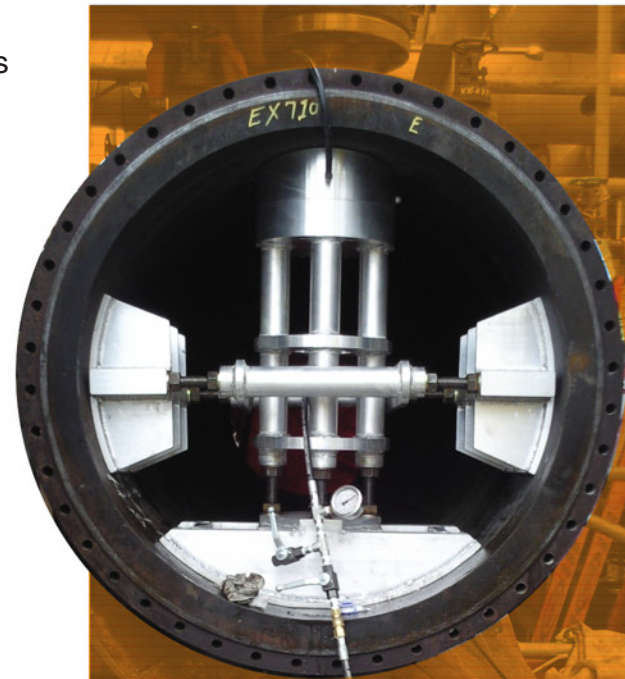

FIGURE 2:

Cross-section of Nozzle Tester for 2" ANSI B16.5 Class 300 Flange

FIGURE 3:
Pressurized Regions
and Areas Defined



CASE STUDY:
No job is too difficult for Furmanite.

When a client approached us about an exchanger application that required an increase in their inlet and outlet size from 4" to 6", our standard OD Nozzle Tester was not an option because the new flanges extended past the channel head. But the client did want to perform the hydrostatic tests locally and without flooding the entire vessel.

In response to the client's unique needs and request, Furmanite custom engineered a specialized tool with an inflatable seal-to-shell connection. It used a jack bolt apparatus to secure the tool inside the barrel while providing cross-support for centering and stabilization.

A large footprint was used to distribute the opposite force evenly against the opposing shell and the results were exactly what the client needed.

What application can Furmanite engineer for you?

Specializing in Custom Applications

Furmanite can provide engineered solutions to accommodate most any Isolation/Weld testing requirements. From our experienced field technicians to our in-house engineering team, our ability to develop custom tools for unique applications is only one of the many things that separate us from the rest. Special applications include, but are not limited to:



- Plain End pipe testing using Grip Tight style tools. These tools are industry proven to test service systems up to the burst pressures of the piping systems.
- Entire service system testing including spool pieces
- Specialty tooling to isolate through valves and hydro test valve welds through the valve body
- Internal diameter nozzle or flange weld testing using priority-designed internal cap with jack bolt type compression device to hold the tool in place
- Under-the-weld Testing – Specialized applications allow Furmanite to test Flange Weld-Slip On, RFWN, Socket Weld, Lap Joint, Lens Ring, O-Ring, Tech-Lock, Grayloc and Orifice-Type flanges.
- Weld-o-lets on pipe for sample valves
- Butt welds on pipe-to-pipe welds

Put Furmanite's Expertise to Work for You

For over 80 years, Furmanite has been considered the worldwide leader in not only Isolation & Weld Testing, but also comprehensive on-site and on-line plant and pipeline maintenance and project services.

Companies around the world in a variety of industries – refining; chemical and petrochemical, nuclear and fossil power generation; gas transmission and processing, oil/gas exploration and production; pulp and paper; food and beverage, pharmaceuticals, steel, marine and many more – have relied on Furmanite for decades to fix leaks in some of the most challenging environments.



By utilizing the service offerings that are part of Furmanite's Turnkey Solution, your organization can avoid costly shutdowns by **"Maximizing your Asset Uptime."**

Furmanite: Solutions for Every Service Need

- On-Line Leak Sealing
- Hot Tapping
- Line Stopping & Line Freezing
- OEM Hot Tap & Line Stop Fittings
- Field Machining
- Line Isolation
- Localized Hydrostatic Weld/Nozzle Testing
- Bolt Torquing & Tensioning
- Torque Tamer™
- Specialty Concrete Repair
- Composite Wraps for Pipe & Vessel Repair
- Tank Roof Repair
- Valve Repair & Valve Asset Management
- Safety Valve Repair
- New Valve & Valve Part Sales
- OEM Wilson Snyder Control Valves and Coker Switch Valves
- Trevitest™ On-Line Valve Testing
- Localized Resistance Electric Heat Treatment
- Combustion Gas-Fired Heat Treatment
- SmartShim™ Conductor Chocking Solutions
- IPSCO™ & SILK™ Brand Equipment Sales

FURMANITE
MAXIMIZING ASSET UPTIME™

Furmanite America, Inc.

101 Old Underwood Road ■ Building F ■ La Porte TX 77571
Phone: 800-444-5572 ■ Fax: 281-842-5111

www.furmanite.com

Preliminary Document. Specifications subject to change. Copyright © 2010 Furmanite America, Inc. All rights reserved. Furmanite, Torque Tamer, Trevitest, SmartShim, IPSCO, SILK and the Furmanite logo are registered trademarks of Furmanite, Inc. Maximizing Asset Uptime is a registered service mark of Furmanite, Inc. All other trademarks, service marks, registered trademarks, or registered service marks mentioned in this document are the property of their respective owners. Produced in USA.